

RS 9040



Warning

Forward this manual to the person responsible for Installation, Operation and Maintenance of the product described herein. Without access to this information, faulty Installation, Operation or Maintenance may result in personal injury or equipment damage.

Installation, Operation and Maintenance of Airflex[®] Models AD, ADP, BD and FDA Rotorseals

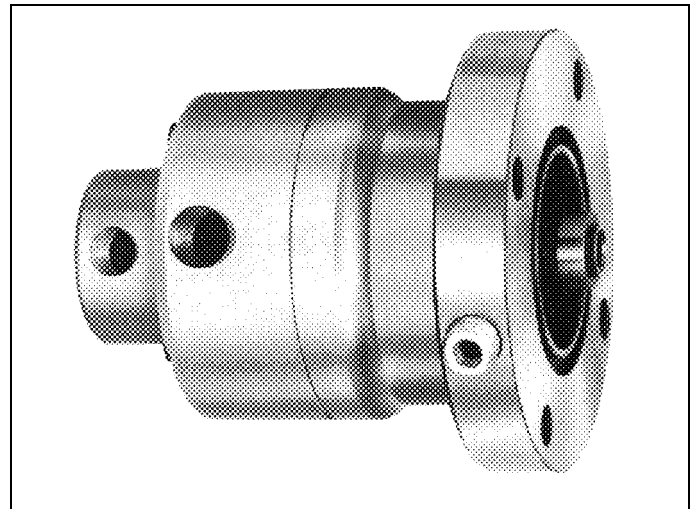

联系方式：

信德迈科技（北京）有限公司 CNMEC Technology Company

地址：北京市朝阳区望京SOHO-T1-C座2115室 邮编：100102

*Tel: 010-8428 2935 | * Fax: 010-8428 8762

*电子邮件：sales@cnmec.biz

主页：http://www.cnmec.biz

*手机：139 1096 2635（微信同号）

“ Since 2007, Strong Distribution, Powerful Partnerships ”



Caution:

Use Only Genuine Airflex[®] Replacement Parts

The Airflex Division of Eaton Corporation recommends the use of genuine Airflex replacement parts. The use of non-genuine Airflex replacement parts could result in substandard product performance, and may void your Eaton warranty. For optimum performance, contact Airflex:

In the U.S.A. and Canada:: **800-233-5926**

Local:(**216**) **281-2211**

FAX: (**216**) **634-8341**

Internet: **www.airflex.com**

October, 1995
204094

(Revised August 2002)

Copyright Eaton Corp. 2002. All rights reserved.

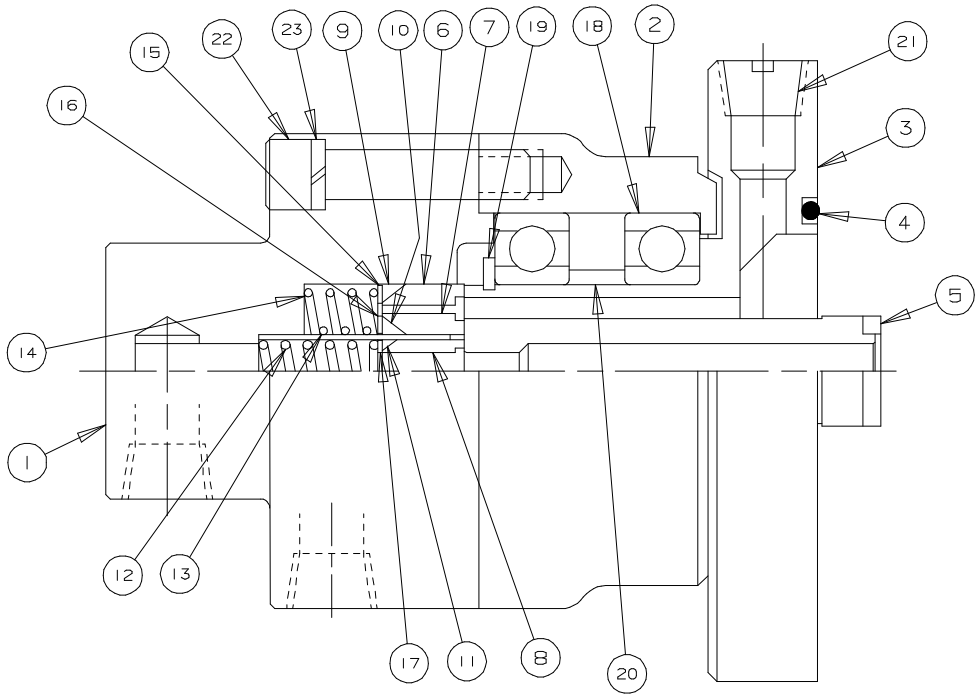

TYPE BD

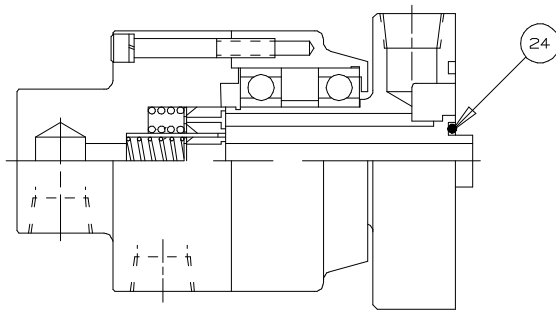

TYPE FDA

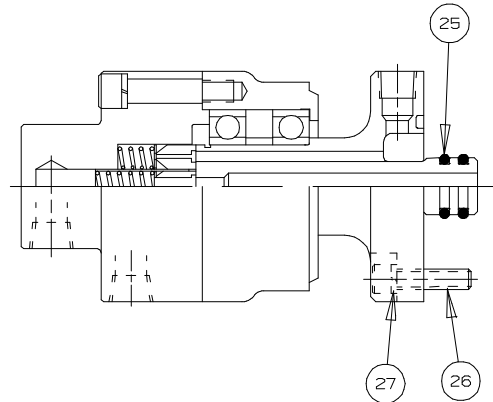

TYPE AD

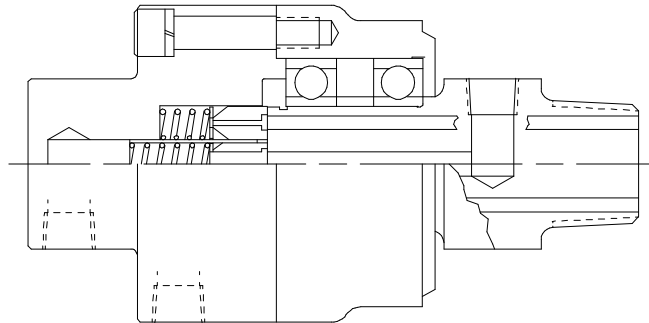

TYPE ADP

Figure 1

Parts for Figure 1						
Model			AD	ADP	BD	FDA
Parts List Number (Basic assembly)			145785C	145785B	145405T	145583AJ
Item	Qty.	Description	Part Number	Part Number	Part Number	Part Number
1	1	Rear Housing	303162	303162	303162	303297
2	1	Front Housing	303163	303163	303163	302588
3	1	Shaft	409530	406208	409536	409452
4*	1	O-ring	000350x0005	N/A	000350x0009	000350x0010
5*	1	Washer	N/A	N/A	000072x0020	N/A
6*	1	Outer Carbon	011010	011010	011010	202164
7*	1	Intermediate Carbon	011011	011011	011011	202161
8*	1	Inner Carbon	011012	011012	011012	202158
9*	1	Outer O-ring	000073x0208	000073x0208	000073x0208	000073x0207
10*	1	Intermediate O-ring	000073x0210	000073x0210	000073x0210	000073x0205
11*	1	Inner O-ring	000073x0209	000073x0209	000073x0209	000073x0206
12*	1	Inner Seal Spring	011013	011013	011013	202159
13*	1	Intermediate Spring	011014	011014	011014	202162
14*	1	Outer Seal Spring	011015	011015	011015	202165
15*	1	Outer retainer ring	008913	008913	008913	202166
16*	1	Intermediate retainer	008914	008914	008914	202163
17*	1	Inner retainer ring	008915	008915	008915	202160
18	2	Bearing	000159x0029	000159x0029	000159x0029	000159x0083
19	1	Snap Ring	000118x0003	000118x0003	000118x0003	000139x0037
20	1	Bearing Spacer	305164-01	305164-01	305164-01	305138-01
21	‡	Pipe Plug	000077x0002 (1) each	N/A	00077x0002 (1) each	000073x0003 (2) each
22	4	Socket head screw	000030x0109	000030x0109	000030x0109	000030x0011
23	4	Lockwasher	000031x0001	000031x0001	000031x0001	000031x0002
24*	1	O-ring	N/A	N/A	N/A	000350x0002
25*	2	O-ring	000073x0015	000073x0015	N/A	N/A
26	4	Screw	000001x0106	N/A	000030x0205	000030x0207
27	4	Lockwasher	000068x0004	N/A	N/A	N/A
Repair Kit			145785X	145785X	145405Z	145583X

* These parts are furnished with the Rotorseal Repair Kit.

‡ Quantity shown () below to part number.

1.0 INTRODUCTION

Throughout this manual there are a number of **HAZARD WARNINGS** that must be read and adhered to in order to prevent possible personal injury and/or damage to the equipment. Three signal words "**DANGER**", "**WARNING**", and "**CAUTION**" are used to indicate the severity of the hazard, and are preceded by the safety alert symbol .



Danger:

Denotes the most serious injury hazard, and is used when serious injury or death WILL result from misuse or failure to follow specific instructions.





Warning:

Used when serious injury or death MAY result from misuse or failure to follow specific instructions.



Caution:

Used when injury or product/equipment damage may result from misuse or failure to follow specific instructions.

It is the responsibility and the duty of all personnel involved in the installation, operation and maintenance of the equipment on which this device is used to fully understand the  **Danger:**,  **Warning:** and  **Caution:** procedures by which hazards are to be avoided.

1.1 Description

- 1.1.1 The Airflex dual passage rotorseals are a reliable means for simultaneously introducing air under pressure to two rotating members on the same shaft. These rotorseals operate continuously or intermittently at high speeds in either direction. Four types are available
- 1.1.2 Type AD has 1/4-18 inlet ports for each of the passages. Both passage outlets can discharge directly into the shaft end. An optional 1/4-18 outlet port in the mounting flange could be used for the outer passage. The inner passage shaft extension is sealed on its outside diameter by a pair of "O" rings. The outer passage is sealed to the shaft end with a compression seal.

- 1.1.3 Type ADP rotorseal attaches to the shaft end with a 1-11 1/2" thread outlet instead of a mounting flange. The outer passage outlet feeds into the end of the machine shaft. The inner passage is a 1/4-18 port located on a flat of the hex mounting nut.
- 1.1.4 Type BD is similar to the AD, except for a larger diameter mounting flange. The inner passage is sealed with a flat washer which compresses on the bottom of a counterbore in the shaft end. A compression grommet is used between the shaft end and mounting flange to seal the outer passage
- 1.1.5 The FDA type rotorseal has larger passages than the BD rotorseal. The two inlet ports and the two flange outlet ports for the outer passage are 1/2-14. Compression seals are used between the shaft end and mounting flange to seal the inner and outer passages. Consult the factory when contemplating the use of Airflex rotorseal with mediums other than air.



Caution:

The factory must be consulted when contemplating the use of Airflex rotorseals with mediums other than air.

1.2 How It Works

- 1.2.1 The sealing between the stationary housing (1) and the carbon seal ring (7), occurs at the lapped seal face of the rotating shaft (3). Coil springs (12),(13) & (14) keep the carbon seal ring in place assuring a positive seal between the components.

2.0 INSTALLATION

2.1 Preparation

- 2.1.1 For AD, BD & FDA rotorseals see Figure 2 and Table 1 for shaft end machining. The ADP rotorseal uses a 1" 11/12 NPT thread on shaft center.

2.2 Mounting

- 2.2.1 Airflex dual passage rotorseals AD, BD & FDA are designed for flange mounting to the machinery shaft or assembly.

2.2.2 Figure 3 shows typical shaft drilling when one outlet is required outboard of the shaft support bearing. This outlet can be the one provided in the mounting flange of the rotor seal. The second outlet, between the shaft bearings, requires an axial hole and cross drilling.

2.2.3 Figure 4 shows typical shaft drilling when both outlets are between shaft bearings. A bayonet assembly, consisting of a length of steel tubing properly supported at both ends, is inserted into the axial hole. The inner passage is the inside diameter of the tube. Rubber seals are used at the inner bayonet support to seal the passages from each other.

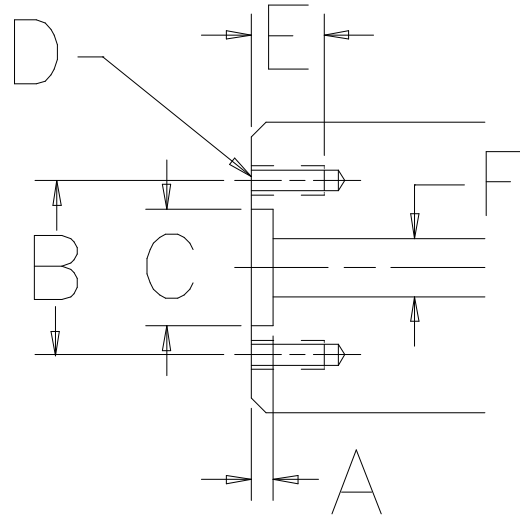

Figure 2

Table 2						
Model	Shaft end machining dimensions					
	A	B	C	D	E	F
AD	.810"	2.562"	.800"	5/16-18	.560"	.380"
BD	.395"	3.562"	.751"	3/8-16	.500"	.380"
FDA	.310"	3.562"	.751"	3/8-16	.750"	.500"

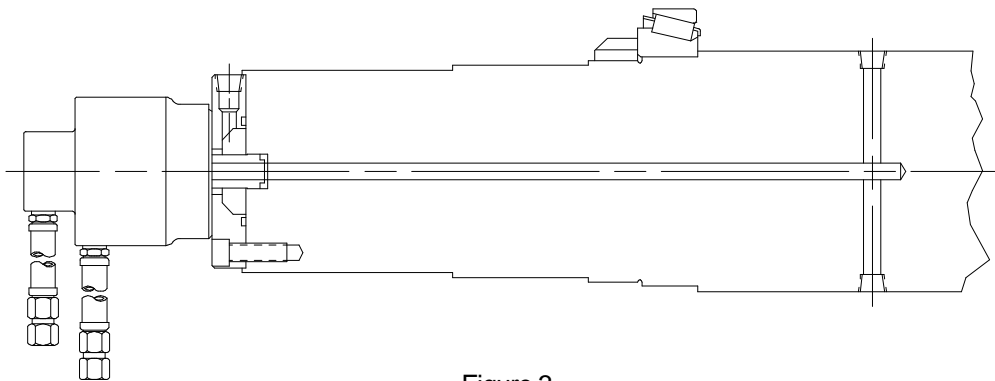

Figure 3

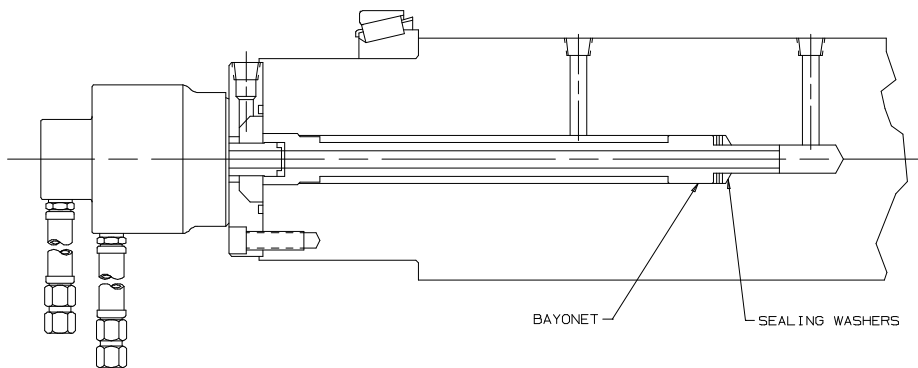

Figure 4

- 2.2.3.1 Be sure the flange seal (4) is properly seated in the flange groove. The seals (5), (24) or (25) on the shaft extension protruding beyond the flange must also be properly seated prior to mounting. A small amount of Parker[®] O-Lube or machine oil may be applied to the shaft o-rings to ease installation.
- 2.2.3.2 Mount rotorseal with mounting screws (26) and lockwashers (27) and torque to 25 ft. lbs. (dry).
- 2.2.4 The Airflex ADP rotorseal has a threaded shaft for direct and easy mounting to the shaft or assembly. The external threads are 1" 11 1/2 NPT.
- 2.2.4.1 Apply a good pipe thread sealant to the thread on the rotorseal shaft. Thread this assembly into the shaft mounting.

2.3 Air connection

- 2.3.1 The rotorseal housing has two pipe threaded air inlets. The AD, ADP & BD rotorseals have 1/4-18 NPT inlets, the FDA rotorseal has 1/2-14 NPT inlets. The connection to the rotorseal should always be through flexible hoses and the air supply piping should be self supporting. Rigid air connections will tend to preload the rotorseal bearings and should be avoided.
- 2.3.2 A good pipe thread sealant should be used when connecting the flexible hoses to the rotorseal.



Caution:

The use of rigid air connections will tend to preload the rotorseal bearings. This will result in poor bearing life and/or bearing failure.

3.0 OPERATION

3.1 Temperature

- 3.1.1 The rotorseal operating temperature is dependent upon the sealing o-ring rubber compounds and/or the type of ball bearings used in the design.
- 3.1.2 The dual passage rotorseals have a maximum operating temperature of 220 °F (104 °C).

3.2 Pressure and Speed Limits

- 3.2.1 Maximum rotorseal pressure and speed limits are shown on Table 1.



Caution:

The operation of Airflex rotorseals at maximum air pressure combined with maximum speed should be avoided. Consult the factory for details of specific application data.

Table 1		
Model	Maximum RPM	Maximum Pressure
AD	1200	150
ADP	1200	150
BD	1200	150
FDA	1000	150

4.0 MAINTENANCE



Warning:

Prior to performing any maintenance on the rotorseal, make sure the equipment is in, and will remain in, a safe condition.

4.1 Periodic maintenance

- 4.1.1 Airflex rotorseals are lubricated for life and require no periodic maintenance. If a rotorseal has become ineffective after prolonged service it can be restored to good operating condition by rebuilding it.

4.2 Rebuilding

- 4.2.1 Replacement kits are available to allow for rebuilding rotorseals in the field. Airflex rotorseals are manufactured of quality materials which are held to precision tolerances. NOTE: Only genuine Airflex rotorseal parts should be used. The rotorseal should be removed from its mounting and repairs should be made in a clean, dust-free environment.

4.3 Disassembly

- 4.3.1 Remove the four socket head screws and lock washers (22) and (23) from the rear housing (1). Hold flange end of the rotor seal in up position and tap to separate housings. When internal parts do not fall free from rear housing (1), the aid of a wire hook may be required to remove same.
- 4.3.2 Where inspection indicates shaft (3) or bearings (18) are in poor condition, either or both must be replaced. If these two parts require disassembly, remove shaft snap ring (19) and press shaft out through bearings. Remove bearings from front housing (2) only if they require replacement.

4.4 Cleaning and Inspection

- 4.4.1 Clean all the parts thoroughly after disassembly with a grease cutting solvent.



Danger:

The manufacturer of any grease cutting solvent publishes a Material Safety Data Sheet. This sheet must be read and understood before using the product.

- 4.4.2 Inspect the lapped sealing end of the shaft (3). This sealing surface should be free of scoring and excessive wear.
- 4.4.2.1 Inspect the bearings (18) for roughness, end play and contamination. They should be in good condition, free of rust, and should revolve smoothly without any tendency to bind.
- 4.4.3 If the shaft (3) or the bearings (18) are in poor condition, they must be replaced. If these two parts require disassembly, remove the shaft external snap ring (19) and press the bearings from the shaft.
- 4.4.4 Inspect the housing (2) for damage from the outer race of the bearings (18) rotating. Replace the housing if necessary.



Caution:

Only genuine Airflex rotor seal parts should be used (Bearings or shaft can be obtained from the factory separately).

4.5 Assembly

- 4.5.1 Assemble springs (12), (13) and (14), spring retainer rings (15), (16) and (17), o-rings (9), (10) and (11) and carbon rings (6), (7) and (8) as shown in illustration. NOTE: O-rings should firmly seal on the chamfered surfaces of carbon seals.
- 4.5.2 Spacer ring (20) should be re-oiled with machine oil for 10 to 20 minutes before assembly.
- 4.5.3 Press bearing (18) with spacer ring (20) into front housing 2 as shown on Figure 1. Install bearings evenly into the housing to prevent binding.
- 4.5.4 Press shaft through bearings until inner race of front bearing is against shaft shoulder. Inner race of rear bearing must be backed up during this operation to keep outer races in place in front housing. Assemble shaft snap ring (19).
- 4.5.5 Assemble front and rear housings. This should be done with lapped faces of carbon facing upward to prevent internal parts from dropping out of position. Fasten housings (1) and (2) with socket head screws (22) and lock washers (23). Torque screws in a crosswise pattern to 25 ft. lbs. (dry).

5.0 TECHNICAL INFORMATION

- 5.1 In any correspondence regarding Airflex Equipment, refer to the Part Number shown on the housing.

Eaton Corporation
Airflex Division
9919 Clinton Road
Cleveland, Ohio 44144
Inside the U.S.A. and Canada: 800-233-5926
Outside the U.S.A. and Canada: 216-281-2211
FAX: 216-281-3890

Parker O-Lube is a registered trademark of Parker Hanafin Corp.

EATON PRODUCT WARRANTY

Subject to the conditions stated herein, Eaton Corporation warrants to the Purchaser that each new Airflex Product manufactured by Eaton will be free from failures caused by defects in material and workmanship, and will deliver its rated capacity, for a period of twelve (12) months from the date of shipment to Purchaser, provided such Product is properly installed, properly maintained, operated under normal conditions and with competent supervision. Warranty claims shall be made in writing and the part or parts shall, if requested by Airflex Division, be returned prepaid to the Airflex Division for inspection. Upon a determination that a defect exists, Eaton shall thereupon correct any defect, at its option either by repairing any defective part or parts or by making available at Eaton's plant a repaired or replacement part. This warranty does not extend to normal wear parts or components of the Product, such as friction material and friction surfaces.

LIMITATION OF WARRANTY

THE FOREGOING WARRANTY IS EXCLUSIVE AND IN LIEU OF ALL OTHER WARRANTIES WHETHER WRITTEN, ORAL OR IMPLIED. ANY IMPLIED WARRANTY OF MERCHANTABILITY OR FITNESS FOR A PARTICULAR PURPOSE ARE SPECIFICALLY EXCLUDED.

In no event shall Eaton be liable for special, incidental or consequential damages. Eaton's liability arising out of the supplying of such Product, or its use, whether in warranty, contract or otherwise, shall in no case exceed the cost of correcting defects in the Products as herein provided. Upon expiration of the twelve (12) month period, all such liability shall terminate. THE FOREGOING SHALL CONSTITUTE THE SOLE REMEDY OF PURCHASER AND THE SOLE LIABILITY OF EATON.

联系方式：

信德迈科技（北京）有限公司 CNMEC Technology Company
地址：北京市朝阳区望京SOHO-T1-C座2115室 邮编：100102
*Tel: 010-8428 2935 | * Fax: 010-8428 8762
*电子邮件：sales@cnmec.biz
主页：http://www.cnmec.biz
*手机：139 1096 2635（微信同号）

“ Since 2007, Strong Distribution, Powerful Partnerships ”